

Engine 4TNV98CT  
Engine power 53,7 kW - 73,0 HP  
Operating Weight 5.470 - 5.720 kg

**ETL 200 T<sub>4</sub>**

**Concrete solutions. Always**



# TECHNICALS SPECIFICATIONS

Operating weight with rubber tracks	kg	12.059
Operating weight with steel tracks	kg	12.059
<b>ENGINE</b>		
Type	YANMAR 4TNV98CT EU Stage IIIB EPA Tier 4	
Max Power (2.600 rpm)	kW - HP	53,7 - 73,0
Max torque	Nm	215 (1.625 rpm)
Displacement	cc	3.319
Number of cylinders	n°	4
Cooling	water	
Consumption	lt/h	11
Alternator	V (A)	12 (80)
Battery	V (Ah)	12 (100/850)
<b>HYDRAULIC SYSTEM</b>		
Pump type	N° 1 with variable displacement axial piston pumps with load sensing REXROTH	
Pump capacity	lt/min	160
Max. circuit calibration pressure	bar	280
High Flow System (standard):		
Max capacity	lt/min	160
Max pressure	bar	280
<b>TRANSMISSION</b>		
Type	Hydrostatic with electro-hydraulic tandem pump and radial pistons REXROTH gearboxes	
Travelling speed	km/h	1 <sup>a</sup> : 0 ÷ 6,2 / 2 <sup>a</sup> : 0 ÷ 12,5
Max Traction force	daN	5.100
Tracks width with rubber tracks (with steel tracks)	mm	450 (340)
<b>BRAKES</b>		
Service brakes	Hydrostatic	
Parking brakes	Negative with multiple disks into oil bath, integrated on the gearboxes at electrohydraulic control	
Emergency brakes	Electrohydraulic control, acting on parking brakes (integrated on the gearboxes)	
<b>PERFORMANCES</b>		
Upsetting load (ISO 14397)	kg	4.100
Operating load (no more than 50% of tipping load)	kg	2.050
Operating load (ISO 14397, no more than 35% of tipping load)	kg	1.435
Teeth breakout force	daN	3.985
Standard bucket capacity	m <sup>3</sup>	0,68
Standard bucket width	mm	2.110
Ground bearing pressure with rubber tracks (with steel tracks)	kg/cm <sup>2</sup>	0,34 (0,47)
Max slope	60% - 30°	
<b>FILLINGS</b>		
Fuel tank	lt	110
Hydraulic oil tank	lt	55
Hydraulic circuit capacity	lt	93
Cooling system capacity	lt	12
Engine oil	lt	6
<b>CONTROLS</b>		
Type	Ergonomic joystick with electronic controls and onboard safety lock	
Translation	Electro-hydraulic control on left hand joystick	
Services	Electric control with right hand joystick for lifting and bucket	
Lifting mechanism	Vertical lifting boom with a standard self-levelling system for the bucket (only for boom rising)	

# ETL 200 T<sub>4</sub>

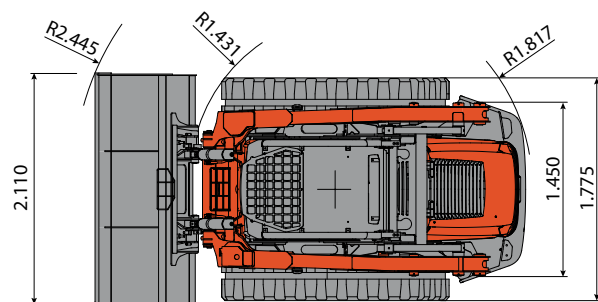
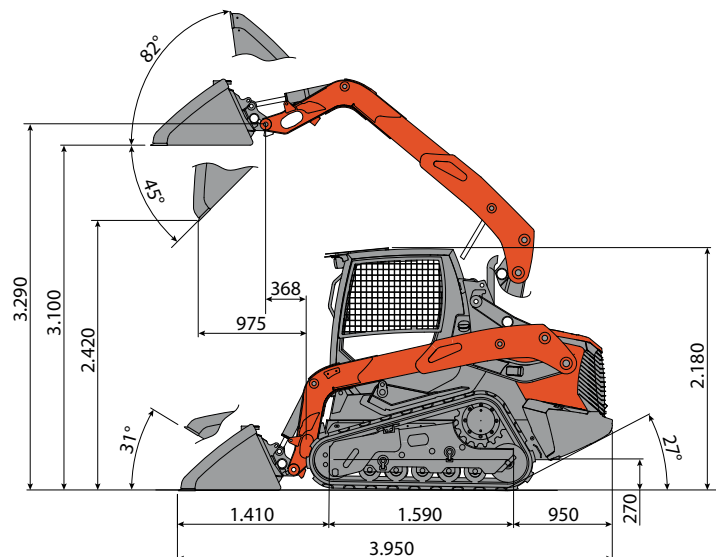

Tracked undercarriage with steering roller system

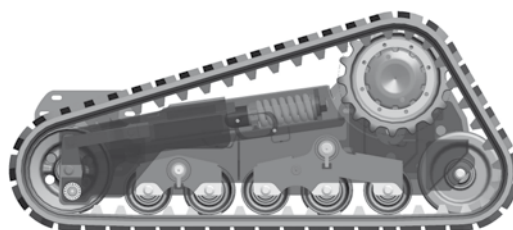

The tracked undercarriages are endowed with a steering rollers system to allow a higher comfort for the worker over rough surfaces.

- Homologation for road traffic (only Italy).
- The ROPS (ISO 3471) – FOPS (ISO 3449) engineer standards manufactured cab or canopy.
- Front and rear lights for night-road use and working.



**EUROCOMACH**



Sampierana S.p.A.

47021 S.Piero in Bagno (FC)  
via Leonardo da Vinci, 40  
Tel +39 0543.904211  
Fax +39 0543.918520  
www.eurocomach.com